

Hand Pallet Truck Top Quality

MODEL NO.LKT 5000

CHAMPLIFT

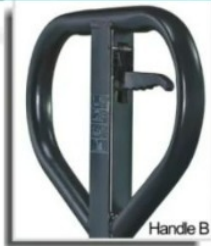

Ergonomic Handle Design

Ergonomic handle ensures the user a relaxed hold and operations.



Durability & Safety

The oil pump body is made of welding the prefabricated parts together first, and then machining the welded body. High-pressure relief valve to prevent overload.



Protective Handle Bumper

Chrome piston and ram for smooth operation and prevents excessive wear on the pump & seal.



Capacity (kg)	5000
Max. fork height (mm)	195
Min. fork height (mm)	85
Fork length (mm)	1150/1220
Width overall forks (mm)	550/685
Steering wheel (mm)	Φ 180x52
Fork wheel (mm)	Φ 80x70
Truck weight (kg)	120/130

- The Special lowering valve facilitates loads being particularly sensitively and proportioned.
- The flexible steering wheel reduces the actual pully effort required.
- Adjustable solid push rods.

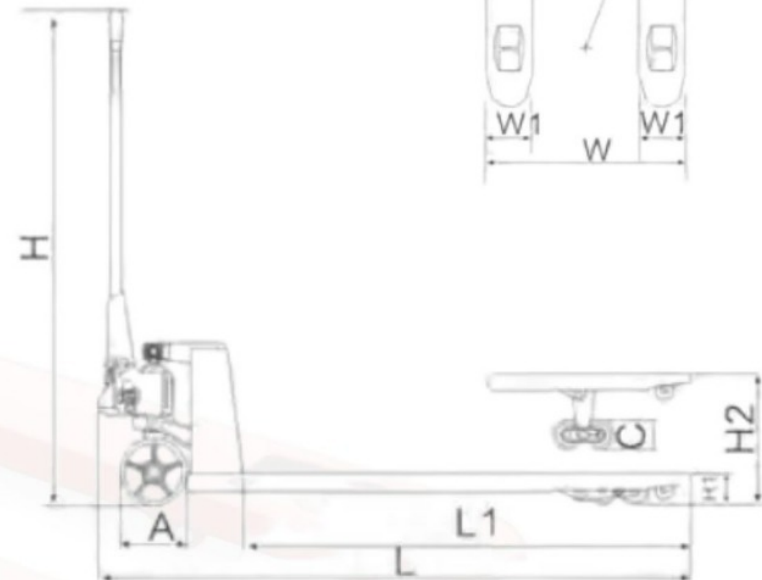
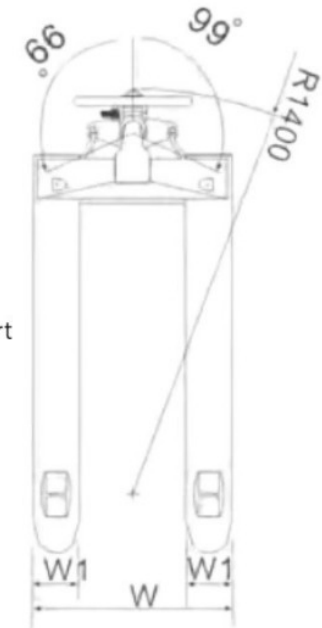

WEIGHT
CAPACITY
5000KG

LOKHANDWALA
TRADING L.L.C.
DUBAI - UAE

Hand Pallet Truck Top Quality

MODEL NO.LKT 2500

CHAMPLIFT



Handle B

Ergonomic Handle Design

Ergonomic handle ensures the user a relaxed hold and operations.



Durability&Safety

The oil pump body is made of welding the prefabricated parts together first, and then machining the welded body High-pressure relief valve to prevent overload.



Protective Handle Bumper

Chrome piston and ram for smooth operation and prevents excessive wear on the pump & seal.



Capacity(kg)	2500
Min.fork height(mm)	75/85
Max.fork height(mm)	185/195
Lifting height(mm)	110
Fork length(mm)	1150/1220
Single fork width(mm)	160
Width overall forks(mm)	550/685
Fork wheel-single(mm)	Φ74×93/Φ80×93
Fork wheel-tandem(mm)	Φ80×70
Steering wheel(mm)	Φ180×50

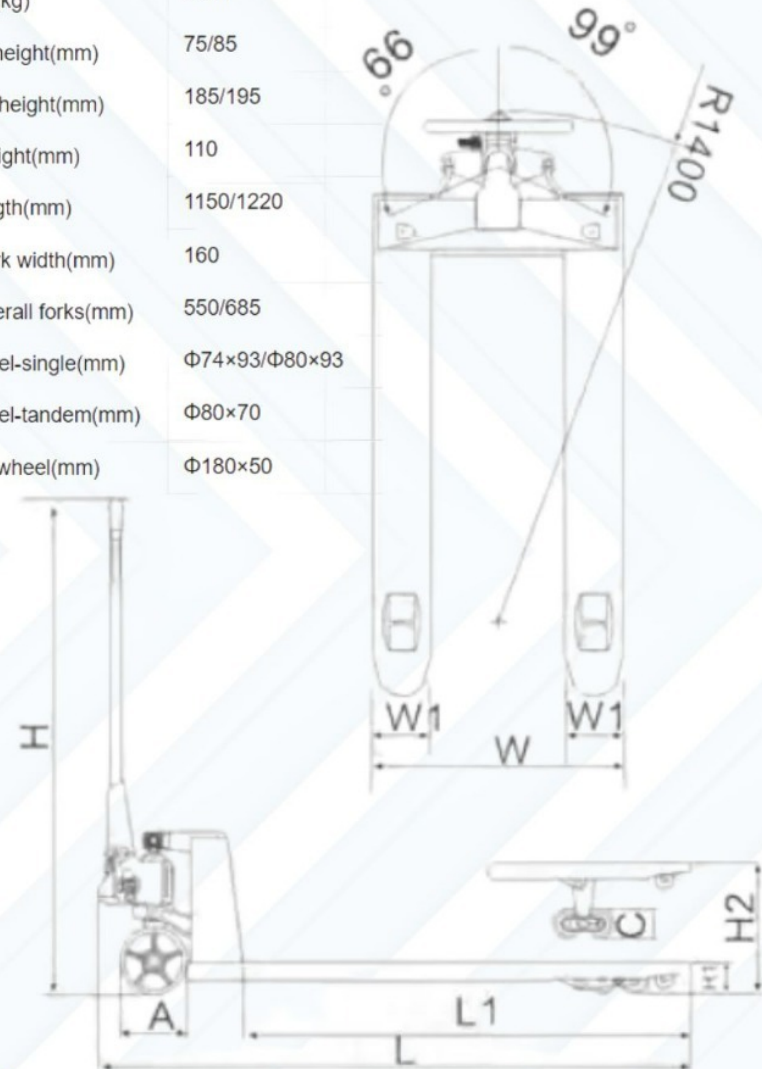

WEIGHT
CAPACITY
2500KG

LOKHANDWALA
TRADING L.L.C.
DUBAI - UAE

Hand Pallet Truck Top Quality

MODEL NO.LKT 3000

CHAMPLIFT



Handle B

Ergonomic Handle Design

Ergonomic handle ensures the user a relaxed hold and operations.



Durability&Safety

The oil pump body is made of welding the prefabricated parts together first, and then machining the welded body High-pressure relief valve to prevent overload.



Protective Handle Bumper

Chrome piston and ram for smooth operation and prevents excessive wear on the pump & seal.

Capacity(kg)	3000
Min.fork height(mm)	85/75
Max.fork height(mm)	195/185
Lifting height(mm)	110
Fork length(mm)	1150/1220
Single fork width(mm)	160
Width overall forks(mm)	550/685
Fork wheel-single(mm)	80X93/74X93
Fork wheel-tandem(mm)	74X70/80X70
Steering wheel(mm)	180X50

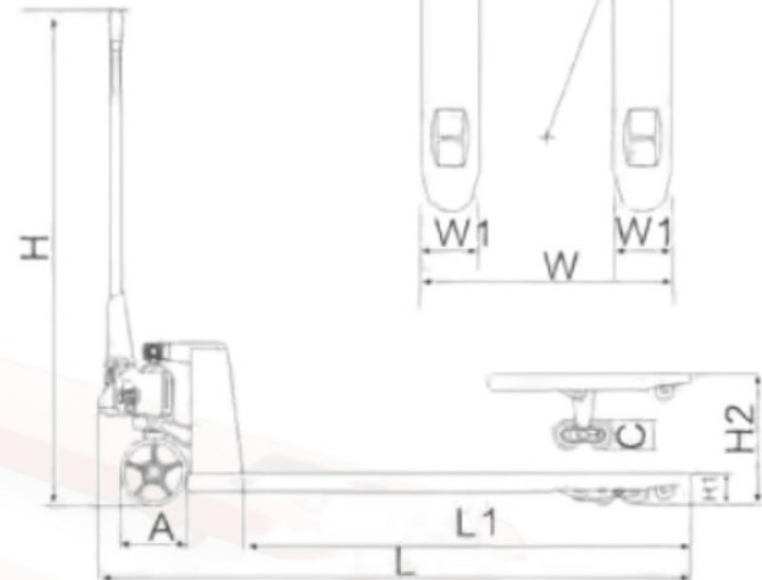
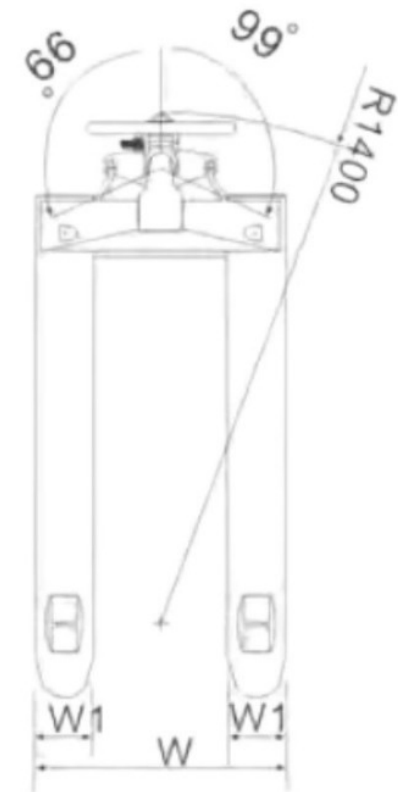

**WEIGHT
CAPACITY
3000KG**



Hand Pallet Truck with Scale

MODEL NO.LKT2500/DIGI

CHAMPLIFT



Ergonomic Handle Design

Ergonomic handle ensures the user a relaxed hold and operations.



Durability&Safety

The oil pump body is made of welding the prefabricated parts together first, and then machining the welded body High-pressure relief valve to prevent overload.

Pallet Truck with scale
Capacity: 2500KG
Measure weight in pounds or kilograms
Measures in 0.5 kg step
Tolerance : +/- 0.5kg
Powered by 1.5VAA Battery
Keypad and automatic tare functions.

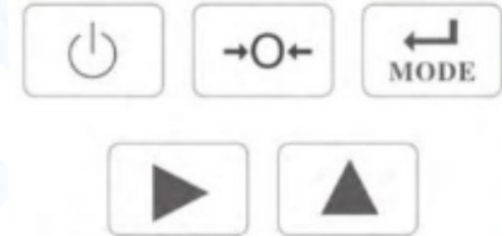

PARAMETER TABLE -----	
Model	LKT2500/DIGI
Capacity (kg)	2500
Total lift height (mm)	175
Lowered fork height (mm)	65
Fork length (mm)	1150
Width overall forks(mm)	550/685
Steering wheel (mm)	⌀ 160x50
Fork wheel (mm)	⌀ 64x70
Truck weight (kg)	109-113

WEIGHT
CAPACITY
2500KG



LOKHANDWALA
TRADING L.L.C.